

# The Time-of-Flight system of AMS02.

## Status Report

F. Anselmo<sup>1)</sup>, M. Basile<sup>1)</sup>, L. Bellagamba<sup>1)</sup>, L. Brocco<sup>1,\*)</sup>, G. Bruni<sup>1)</sup>, D. Casadei<sup>1)</sup>,  
 G. Castellini<sup>2)</sup>, F. Cindolo<sup>1)</sup>, A. Contin<sup>1)</sup>, I. D'Antone<sup>1)</sup>, P. Giusti<sup>1)</sup>,  
 G. Laurenti<sup>1)</sup>, G. Levi<sup>1)</sup>, A. Margotti<sup>1)</sup>, A. Montanari<sup>1)</sup>, F. Palmonari<sup>1)</sup>, L. Patuelli<sup>1)</sup>,  
 A. Pesci<sup>1)</sup>, G. Sartorelli<sup>1)</sup>, C. Sbarra<sup>1)</sup>, C. Williams<sup>1)</sup>, A. Zichichi<sup>1)</sup>

1) University of Bologna and INFN, Bologna, Italy

2) CNR-IROE, Florence, Italy

\*) now at LAPP, Annecy, France

April 16, 2001

### 1. Introduction

After the successful operation of AMS-01 aboard of the Space Shuttle Discovery in a 10-days test-flight carried out in June 1998, the detector has been redesigned to increase the maximum detectable rigidity up to 1 TV, by using a superconducting magnet which will provide a maximum field of about 0.8 T. As a consequence, the TOF system [1] had to be redesigned to operate in a strong magnetic field and with variable values for the angle between the light detectors (photomultiplier tubes – PMs) and the field direction. In the following a description of the new TOF system is given and results are reported on various aspects of the system operation.

### 2. Design considerations

The TOF system, under construction at the INFN Laboratories in Bologna, will provide:

1. the fast trigger to the experiment;
2. the measurement of the time of flight of the particles traversing the detector with a resolution sufficient to distinguish upward from downward going particles at a level of at least  $10^{-10} \div 10^{-11}$ , and electrons from anti-protons up to about  $1 \div 2$  GeV;
3. the measurement of the absolute charge of the particle in addition to the measurement done by the silicon tracker and by the RICH.

As for AMS-01, the main parameters which have been taken into account in designing the detector are:

#### 1. *Total sensitive area.*

To match the full acceptance of the magnet, each plane of the TOF system has to cover a circular area of about  $1.6 \text{ m}^2$ . This is obtained with 12 cm wide scintillator pads of different length, overlapped by 0.5 cm to avoid geometrical inefficiencies (see section 3.2).

#### 2. *Trigger selection.*

The TOF system has to provide the fast trigger to the AMS experiment. For an efficient background rejection, the system consists of two pairs of planes, one before and one after the magnet, with the paddles arranged perpendicularly to each other in the two planes of each pair. This allows for a granularity of about  $12 \times 12 \text{ cm}^2$  for trigger purposes.

#### 3. *Weight.*

Given the strong limitations in the total weight of the AMS detector, the TOF system was allotted only about 250 kg to accommodate for the detector itself, the support structure and the power supply system.

#### 4. *Power consumption.*

The TOF system was allowed to use about 240 W for PMs operation and signal read-out (see section 4).

#### 5. *Time-of-flight resolution*

The resolution in the time of flight needed to satisfy the physics requirements outlined in section 1 is about  $100 \div 200$  ps. The choice made to use 1 cm thick scintillator (see section 3.2), was

a compromise between minimum thickness and the light output needed to reach this resolution.

#### 6. Operation in space.

The operation of the TOF system in space imposes several requirements on the mechanical design and on the electronics for the TOF system. In particular the counters have to be housed into mechanically robust and light-tight covers with a system for fast depressurization, the support structure has to conform to the NASA specifications concerning resistance to load and vibrations and the electronics has to be protected from the highly ionized low-orbit environment. Moreover the system has to guarantee redundancy, hence the choice of having more than one PM on each side of the counters (see section 3.2).

### 3. Mechanics

In the test flight of June 1998, Hamamatsu R5900 photomultiplier tubes were used to detect the scintillation light from the TOF counters in that they provided small occupancy, low power consumption and good time resolution. In order to shield the tubes from the residual magnetic field (200G) the PMs were enclosed in a 0.5 mm thick shielding case made of VACOFLUX permalloy [1].

The AMS-02 superconducting magnet produces a much larger field (about  $2 \div 3$  kG) of variable direction on the TOF planes. Fig. 1 shows the magnetic field magnitude and angle with respect to the vertical ( $z$ ) direction at the vertical coordinates where the TOF planes are positioned. To work in such conditions the light detectors must withstand the magnetic field without shielding, in a large interval of angles with respect to the field direction.

The design of the TOF system for AMS-02 was therefore completely determined by the choice of the light detectors.

#### 3.1. PMs

After a market study, the Hamamatsu R5946 photomultiplier tube (Fig. 2) was considered as the best choice and thoroughly tested for time resolution and pulse height response in magnetic field.

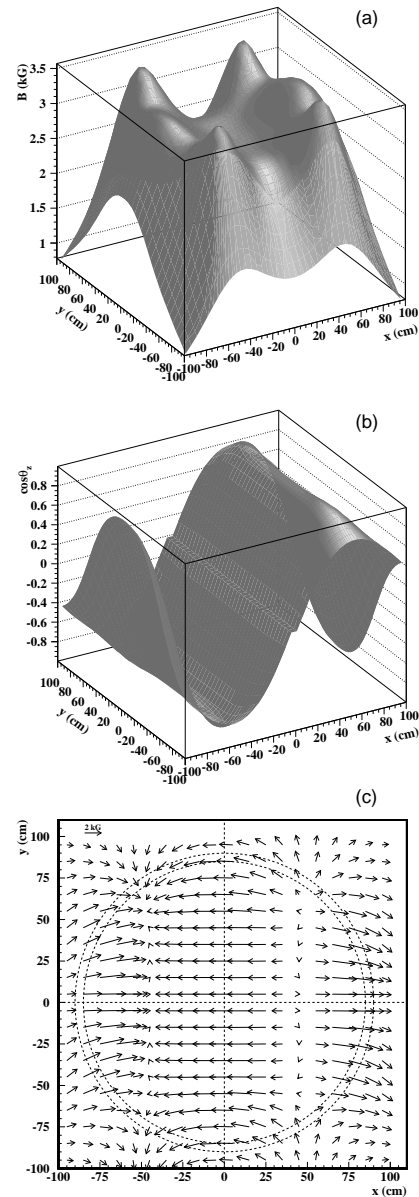

**Figure 1.** The magnetic field magnitude (a), its direction with respect to the  $z$  axis of AMS-02 (b), and its component in the plane at  $z = 60$  cm. The dashed circles in (c) represent the approximate position of the TOF system PMs.

### 3.1.1. The experimental apparatus

The experimental apparatus (shown in Fig. 3) consists in a red light emitting diode (LED) operated through a CAMAC module<sup>1</sup> which provides a variable pulse with amplitude between 0 and  $-20$  V and duration between 5 and 100 ns. The system is clocked at about 20 Hz.

The light is guided to the PM by two optical fibres. The PM is placed inside the poles of an electromagnet (maximum field 4 kG) on a movable stand which can be rotated at a maximum angle of  $90^\circ$ . The charge signal from the photomultiplier is digitized by an ADC<sup>2</sup> with two 12-bits scales (0.25 pC/ channel and 0.033 pC/ channel, respectively) and registered by a PC-based data acquisition system.

### 3.1.2. PMs gain and energy response

The PMs gain has been measured following the method of reference [2].

As the gain of the R5946 PMs show large variations from sample to sample (about a factor of 6), three PMs were selected for testing in magnetic field: one with high gain (PM no. 9386), one with intermediate gain (PM no. 9385) and one with low gain (PM no. 9381). All three PMs were then operated at a gain of about  $2 \times 10^6$ , with voltages of 1700 V, 2000 V and 2200 V, respectively.

The PM responses have been measured for different values of the magnetic field  $B$  and of the angle between the PM axis and the field direction, called  $\theta$  in the following. Figures 4 shows the response of the PMs at different values of the magnetic field, relative to that at  $B = 0$  G, as a function of  $\theta$ . For  $\theta \leq 50^\circ$ , the relative response is greater than 50% up to the highest values of  $B$ . Only at  $\theta = 60^\circ$  the response goes to zero for  $B \geq 1000$  G.

The single photoelectron response has been measured using a very low-level light pulse from the LED for several PM orientations and field magnitudes. The resolution degrades rapidly with increasing magnetic field at large angles and with increasing angle at fixed magnetic field. A summary of the resolution in the single photoelectron response is shown in Fig. 5 for the three PMs and for different values of the magnetic field and of the angle  $\theta$ . The consequence of the worsening of the single photoelectron response with increas-

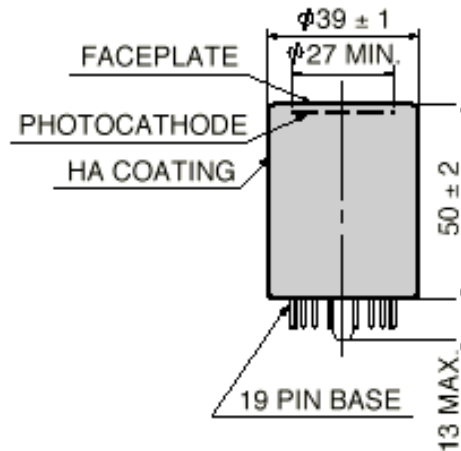

**Figure 2.** The Hamamatsu R5946 photomultiplier tube. The photocathode surface is  $572 \text{ mm}^2$ , much larger than the  $324 \text{ mm}^2$  surface of the R5900 PMs used in AMS-01.

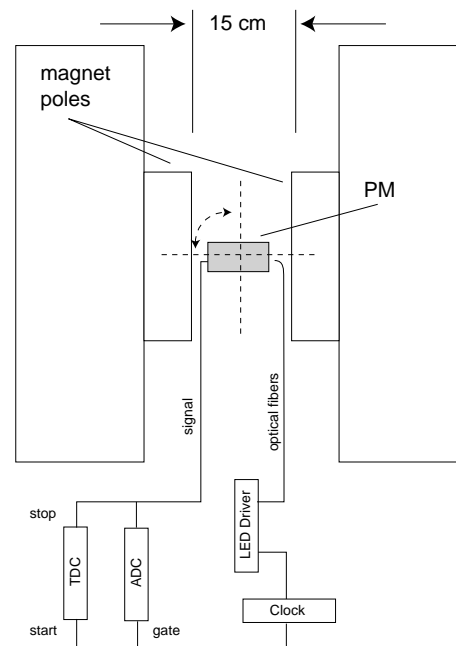

**Figure 3.** The experimental setup used for the measurement of the PM behaviour in magnetic field. The maximum field is about 5 kG.

<sup>1</sup>LED DRIVER fom CAEN, Italy.

<sup>2</sup>CIA fom CAEN, Italy.

ing field and  $\theta$  is a small degradation in the energy measurement resolution, as shown in Fig. 6 for PM no. 9386 when illuminated with a signal equivalent to about 240 photoelectrons.

No relevant difference has been seen between the three PMs.

### 3.1.3. Time resolution

Although the test system has not been designed for a very precise measurement of the time resolution of the PMs, some conclusions on the effect of the magnetic field can nonetheless be drawn.

The signal from the PM is sent to a discriminator (with the threshold set at 30mV) and then to the *stop* input of a 50ps/bin TDC, started by the pulse driving the LED.

The transit times and the time resolutions for PMs no. 9381 and 9386 are shown in Fig. 7 as function of the magnetic field and for different values of  $\theta$ . The most relevant observation is that the PM operated at higher voltage (no. 9381) shows a shorter transit time and a better time resolution. A strong correlation is observed between the time resolution and the transit time for both PMs and a serious degradation in the time resolution is measured for  $\theta \geq 30^\circ$ .

## 3.2. Module design

The design of the new TOF counters is different from AMS-01 in the following points:

- Due to their larger size, only two PMs are accommodated in each side of the counter.
- The light guide is designed so as it can be tilted to various directions. The light is guided independently to each PM on one side.
- Due to mechanical constraints, some of the counters have a clear plastic extension between the scintillator and the light guides.

A picture of one module is shown in Fig. 8. Photographs of sample light guides after tilting are shown in Fig. 9.

## 3.3. TOF plane design

Due to mechanical constraints, each TOF plane consists of 12 counters, 12cm wide instead of 14 counters (11cm wide) as in AMS-01. Also, the PM orientations cannot be completely optimized. Figure 10

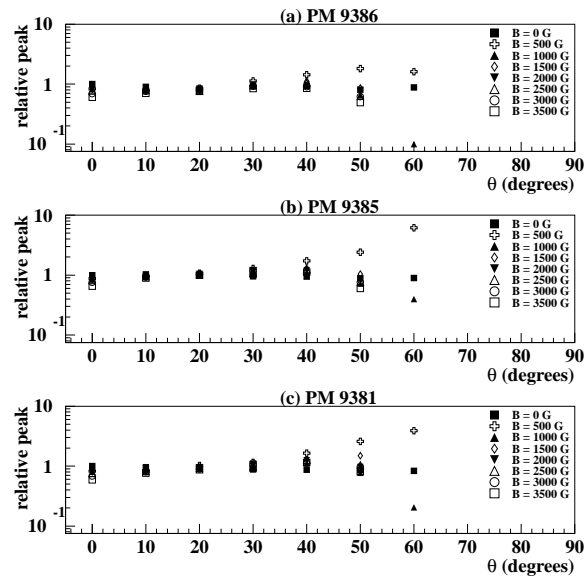

**Figure 4.** The relative response of the three PMs as a function of the angle  $\theta$  between the PM axis and the field direction, for different values of the magnetic field  $B$ . The PM response is seriously degraded for  $\theta \geq 60^{\text{circ}}$ .

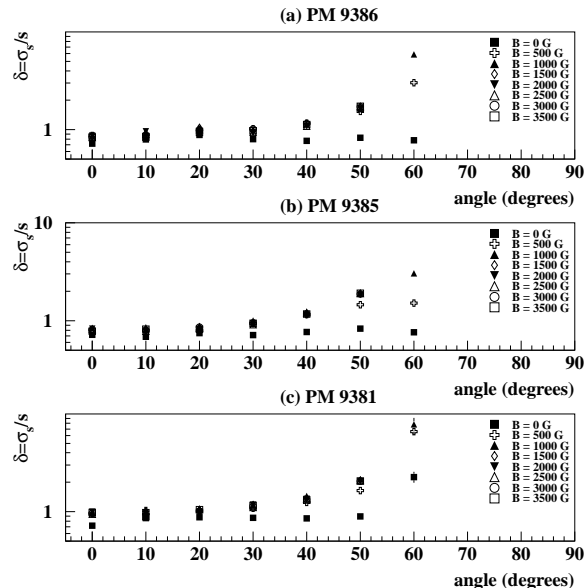

**Figure 5.** Single photoelectron resolution as a function of the angle with respect to the field direction for the three PMs and for different values of the magnetic field.

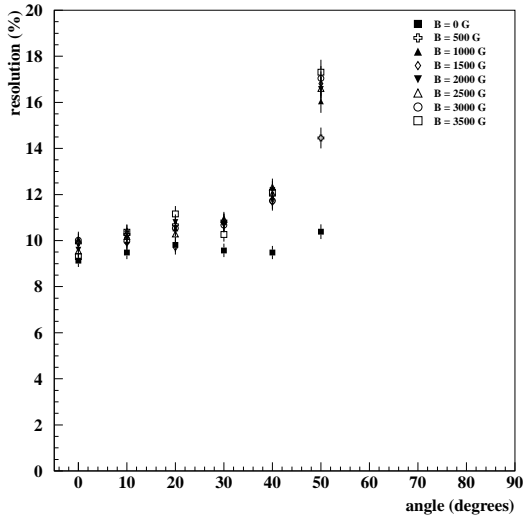

**Figure 6.** Energy resolution for a signal equivalent to a minimum ionizing particle (240 photoelectrons) as a function of the angle with respect to the field direction and for different values of the magnetic field.

shows a principle design of planes 1 and 2 of the TOF system. The PM orientation with respect to the magnetic field and the field magnitude are shown in Fig. 11 for all PMs of the system.

Figure 12 shows the mechanical support structure of both pairs of TOF planes. The counters are attached to a honeycomb plane which is connected to the AMS-02 general support structure (USS2). The bottom honeycomb plane is also used as support for the RICH radiator.

#### 4. Electronics

The main constraints for the TOF electronics are:

- redundancy in order to operate safely in space;
- complete control on every channel for fine tuning during 3 years of data taking;
- low power consumption (150 W), i.e. high efficiency both for power conversion (up to 2400 V and for read-out.

The TOF has 4 planes with 12 counters seen by 2 PMs at each side, for a total of 192 PMs. The signals from

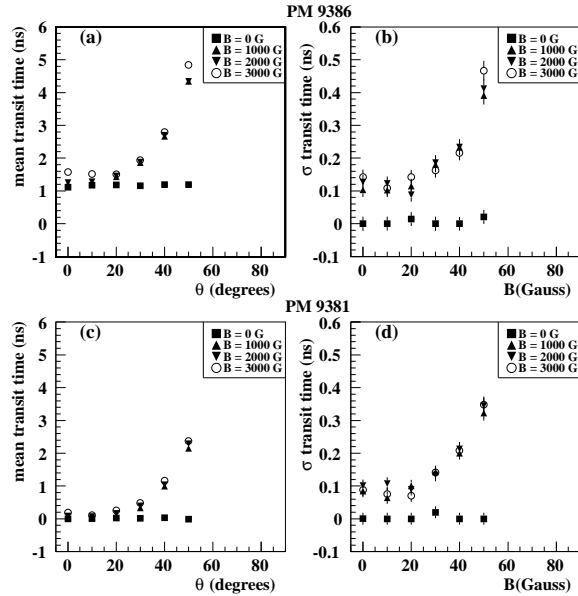

**Figure 7.** Time delay with respect to LED pulse (“mean transit time”) and time resolution as function of the magnetic field and for different values of  $\theta$  for PM no. 9386 (a,b) (higher gain – lower voltage: 1700 V) and PM no. 9381 (c,d) (lower gain – higher voltage: 2200 V). The mean transit times are referred to the transit time of PM no. 9381 at  $B = 0$  G. The time resolution at  $B = 0$  G is subtracted. The PM operated at higher voltage shows the shorter transit time and the best time resolution.

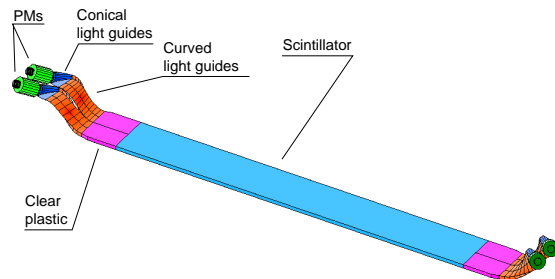

**Figure 8.** General TOF counter design. The configuration of the light guides and the dimension of the clear plastic section are different for counters in different positions.

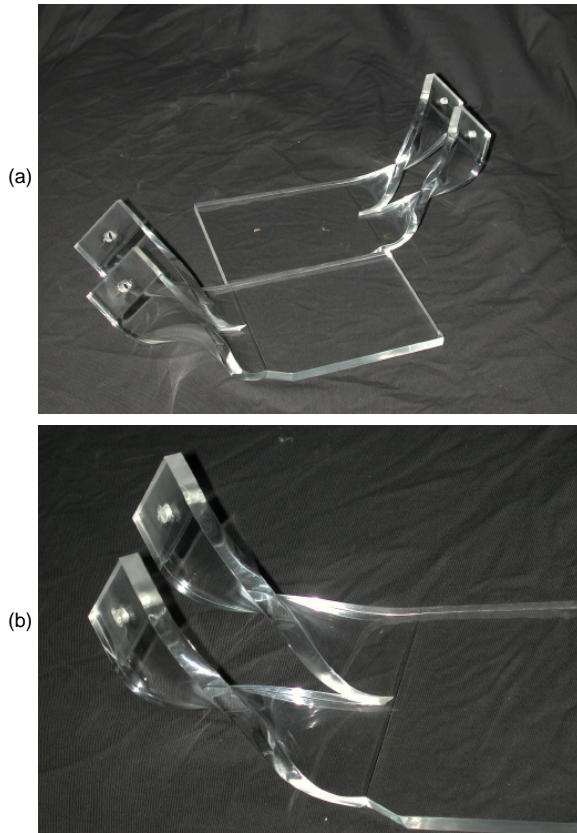

**Figure 9.** Photographs of sample light guides after tilting. The straight section on top of the guide has a hole to hold it during tilting and will be cut away before mounting.

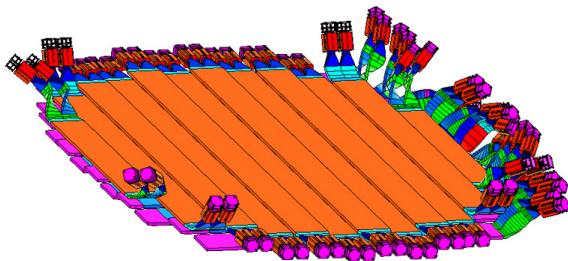

**Figure 10.** Sketch showing the positioning of the counters and of the PMs in planes 1 and 2 of the TOF system. Note that the PMs of plane 1 are shown on one side only.

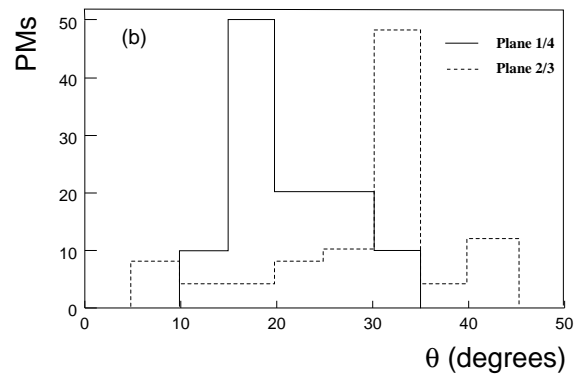
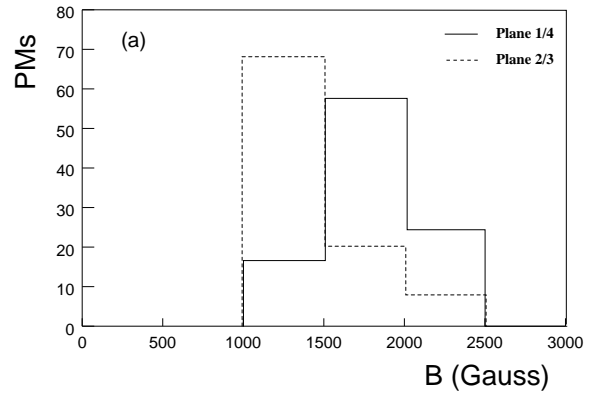

**Figure 11.** Magnetic field (a) and angle between the PM axis and the magnetic field direction for PMs (b) on planes 1 and 4 (full line) and planes 2 and 3 (dashed line), respectively. For planes 2 and 3 the magnetic field direction is nearly perpendicular to the PM direction (see Fig. 1): this gives, on average, larger  $\theta$  angles.

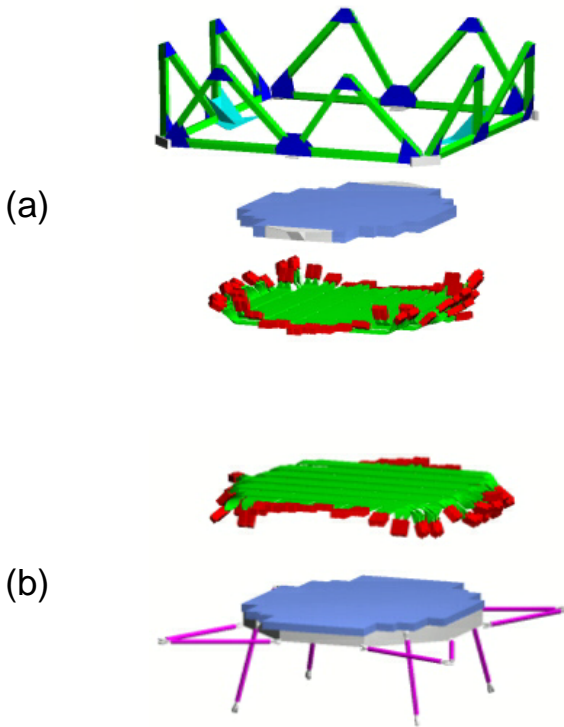
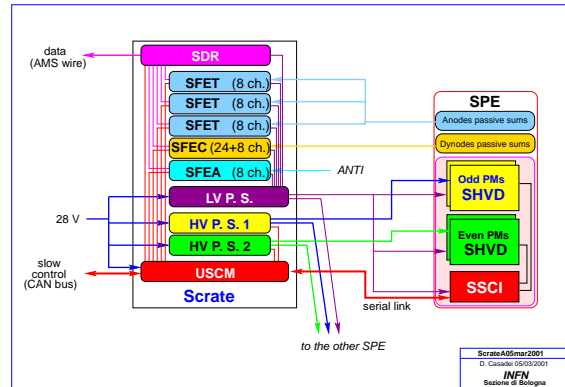

**Figure 12.** Mechanical support structure of top (a) and bottom (b) TOF planes. The upper structure is attached to the TRD support; the lower serves also as support for the RICH radiator.

the two PMs on each side of the scintillator paddle will be summed to provide one signal from the anodes and one from the 3<sup>rd</sup> last dynodes. The anodes signal will be used for time measurement in a way similar to AMS-01, while the dynodes signal will be used for charge measurement using linear ADCs, in order to have a better charge measurement than for the TOF system of AMS-01.

The TOF electronics will be housed in two pairs of crates (see Fig. 13), each pair servicing one pair of planes and containing the PM power supplies (see section 4.2) and the read-out electronics (see section 4.3). Part of the electronics will be positioned near to the counters (see Fig. 14) to minimize the high voltage cable length.

Most of the electronics described in the following is presently in an advanced design and/or prototyping phase.



**Figure 13.** TOF electronics crate. SDR=Scintillator Data Reduction; SFET=Scintillator Front-End Time; SFEC=Scintillator Front-End Charge.

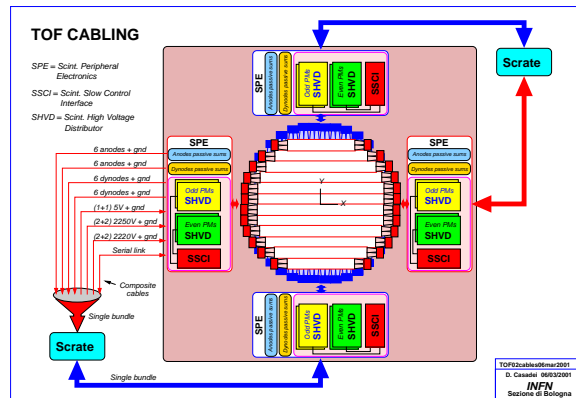

**Figure 14.** The TOF peripheral electronics. SHVD = Scint. High Voltage Distributor; SSCI = Scint. Slow Control Interface.

#### 4.1. Voltage dividers

In order to reduce power consumption, the voltage divider of the TOF PMs will have a total impedance of  $80\text{M}\Omega$ . The measured maximum rate with the first prototype is of 10 kHz, much larger than the expected trigger rate (between 100Hz and 1000Hz).

The validity of this choice is confirmed by the good behavior of the TOF system of AMS-01, that was able to keep a 99.98% trigger efficiency over all geomagnetic coordinates (with the exception of the South Atlantic Anomaly).

#### 4.2. PM power supplies

The 24 PMs on the same side of a plane will be connected to 2 power supplies, one for the 12 “odd” PMs, the other for the 12 “even” PMs, to increase redundancy. Moreover, each power supply will have two sides, one “hot” and one “cold”, which will only be powered in case of failure of the “hot” side.

The HV from the power supply will be distributed to 12 regulators, sitting near to the counters, with a current limiter as protection against short circuits.

#### 4.3. Read-out

Each electronics crate will house:

- one *Scintillator Data Reduction* (SDR) board collecting data from three *Scintillator Front-End Time* (SFET) measurement boards reading 8 TOF channels each;
- one *Scintillator Front-End Charge* (SFEC) measurement board connected to 24 TOF channels and 8 anticoincidence channels;
- one *Scintillator Front-End Anticoincidence* (SFEA) board reading 8 anticoincidence channels.

Each board will be doubly redundant (“hot” and “cold” sides).

#### 4.4. Slow control

The slow control functions of the TOF system will be executed by two boards:

- The *Universal Slow Control Module* (USCM) will sit in the crate and it will have the complete control over all the electronic boards of its crate and will be connected to 2 *Scintillator*

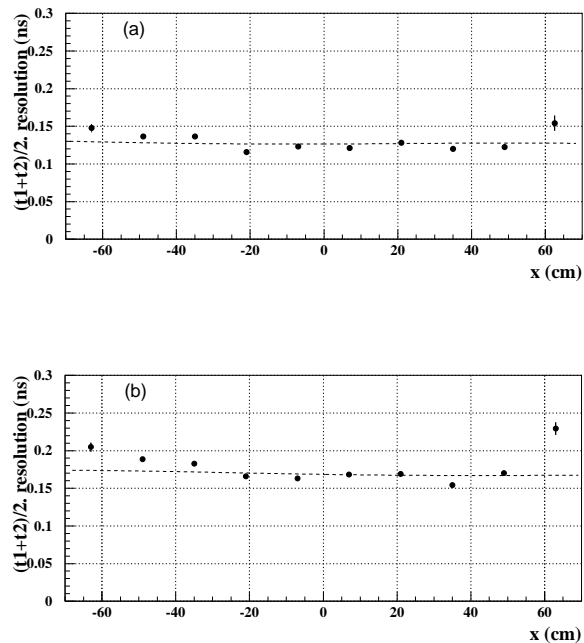

**Figure 15.** Results of the tests with the new R5946 PMs: time resolution as a function of the position along the counter for straight light guides (a) and curved light guides (b).

*Slow Control Interface* (SSCI) units placed near the PMs through serial links.

- The SSCI board which is responsible for setting and reading the HV of a plane side.

The temperature of the TOF system will be read by the USCM. The latter will also turn on and off each board in the crate, selecting the “hot” or “cold” sides, and it will get the voltage and the current values from the same boards.

## 5. Test results

In order to determine the effects of the new PMs and of the new light guide design, the time resolution of two counters equipped with Hamamatsu R5946 PMs and with different light guide design have been measured using minimum ionizing particles selected with a cosmic ray telescope.

Figure 15 shows the time resolution as a function of the position along the counter for straight light guides and for light guides tilted at  $90^\circ$  with respect to the

counter plane. The resolution for straight guides is similar to what was obtained with the AMS-01 counters. The observed worsening of resolution for tilted guides indicates that about half of the photoelectrons are lost due to the unfavourable geometry.

## 6. Conclusions

Based on the measurements given in section 3.1, the AMS-02 TOF system will have a worst time resolution then in AMS-01, due to the tilted light guides and to the effect of the magnetic field. In particular, several of the PMs will have an angle with respect to the magnetic field direction greater than  $30^\circ$ . Figure 16 shows the expected resolution in  $\beta$  as a function of the time resolution of the TOF system. As a worst case, if only two planes are used to compute  $\beta$ , the expected resolution would be  $\Delta\beta/\beta = 3.7\%$  (at  $\beta=1$ ) and positrons could be identified against protons up to about 1.3 GeV.

## REFERENCES

- [1]D. Alvisi *et al.*, Nucl.Instrum.Meth. A437 (1999) 212.  
 [2]B. Bencheick *et al.*, Nucl. Instrum. and Methods A315 (1992) 349.

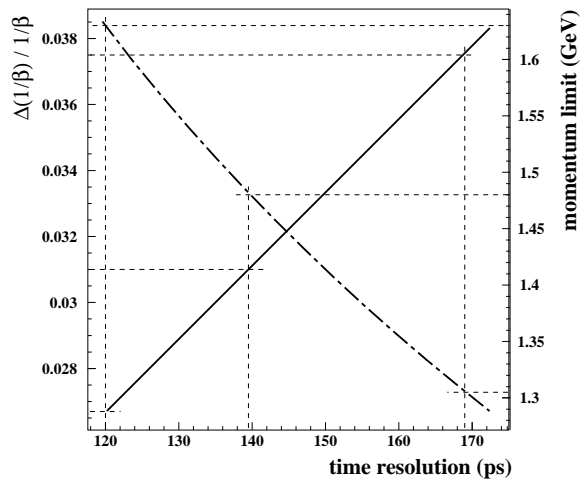

**Figure 16.** Expected resolution in  $1/\beta$  (full line – left scale) and momentum limit for positron identification (dashed-dotted line – right scale) as a function of the TOF system resolution. Th dashed lines correspond to three cases: 120ps: 4 planes; 140ps: 3.5 planes (as in most of AMS-01 flight); 170ps: 2 planes.